

**German Investment Seminar
Dresdner Kleinwort Wasserstein, New York**

January 13, 2004

ThyssenKrupp



ThyssenKrupp Group 2002/2003

ThyssenKrupp AG

Group sales (consolidated): €36.1 billion • EBT (consolidated): €714 million • Employees: 190,102

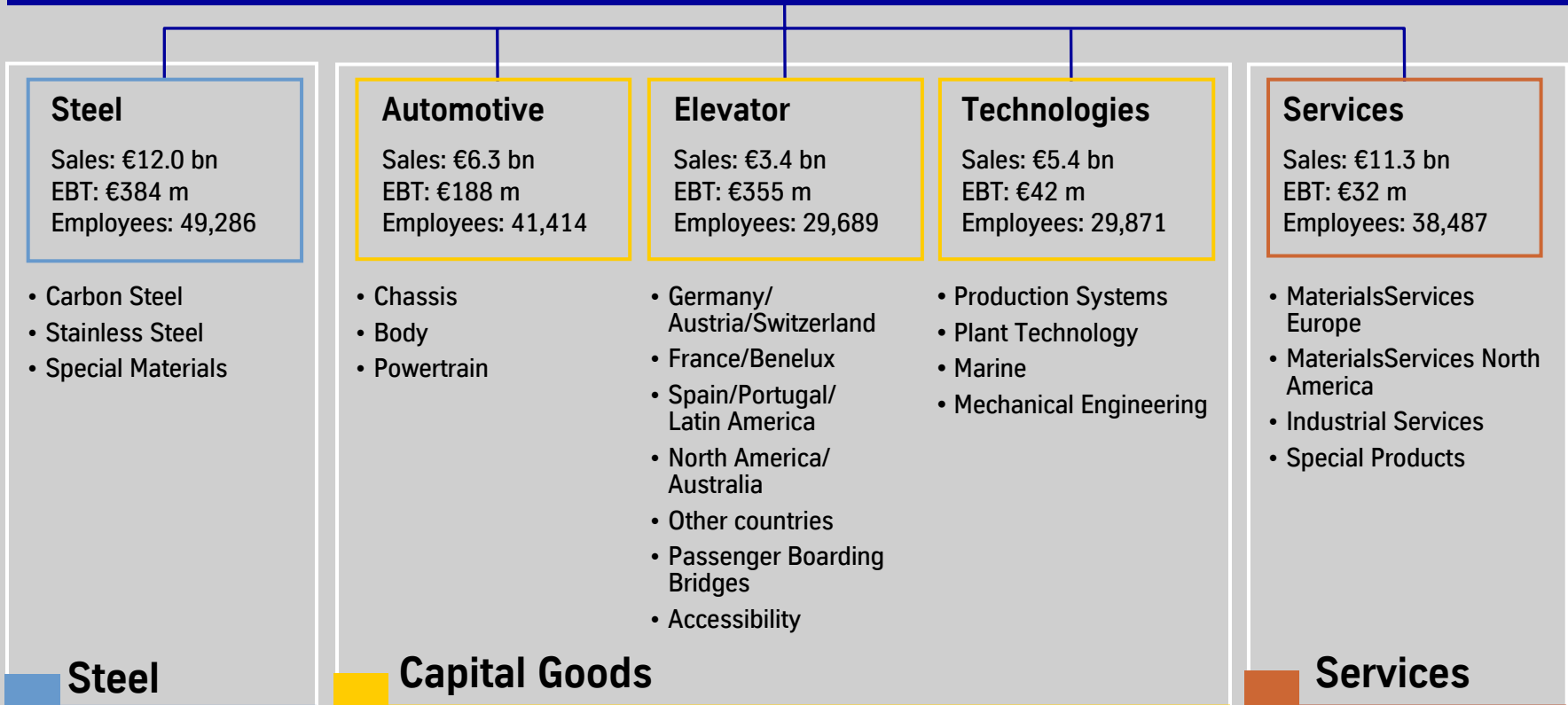

Inter-segment sales unconsolidated; employees on Sept. 30, 2003



Elements of Strategy

- Development of technically advanced products

 - High technological capabilities and innovative strength
 - ⇒ 3,000 engineers in 40 R&D centers
 - ⇒ approx. €640 m for R&D projects in the Group

 - Optimal utilization of potential in the Group
 - ⇒ Harness cross-selling effects
 - ⇒ Technological developments across segments
 - ⇒ Groupwide access to know-how through knowledge management

 - Value-based management: integrated controlling strategy and continuous value reporting

 - Intensified customer focus

 - Stronger Groupwide service focus
 - ⇒ Development of new service applications
-



ThyssenKrupp Steel

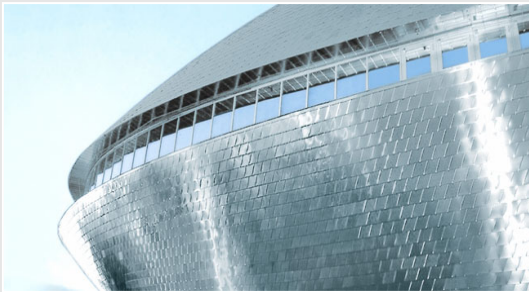
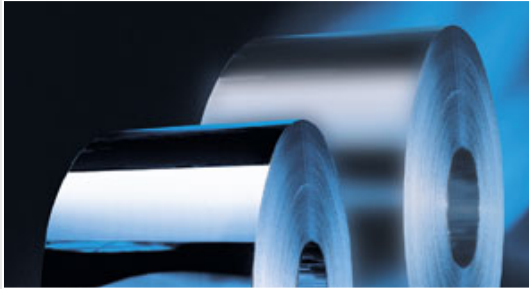

- European No. 2 and world No. 6 in carbon steel flat products
- World market leader in stainless steel flat products, nickel-base alloys, electrical steel and tailored blanks
- Focus on flat products with high value added
- Profit leader in Europe through: portfolio optimization, investment policy, performance enhancement
- Site configuration unique in Europe: 17.3 mt/yr crude steel capacity in Duisburg
- Innovation leader in products and processes
- International presence further strengthened with production facilities in the world's growth markets; systematic development of global strategic alliances



ThyssenKrupp Automotive

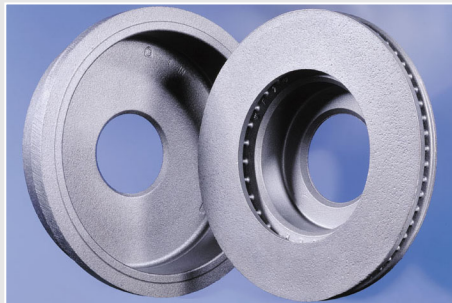
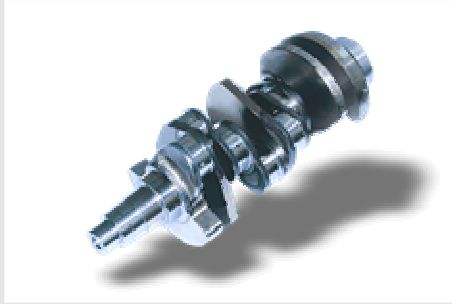

- 80% of sales from TOP 3 positions
- Sales growth to €10 billion through organic growth and acquisitions
- Technology leadership in product and process technologies
- Materials capabilities: processing of all key materials like iron, steel, aluminum, magnesium, plastic
- Parallel expansion of component and system business capabilities
- Further participation of outsourcing trends of automobile manufacturers
- Expansion of presence in Asia and increase in deliveries to Asian OEMs

ThyssenKrupp Elevator

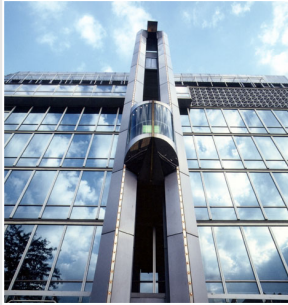

- No. 3 on world market, top global market positions
- 700,000 service contracts worldwide
- Full range of products and services from a single source
- Strong service network – benefiting from full maintenance products
- 50% of segment sales through services
- Increase market share globally and locally, especially in Asia
- Growth to continue through further acquisitions and even stronger focus on services

ThyssenKrupp Technologies

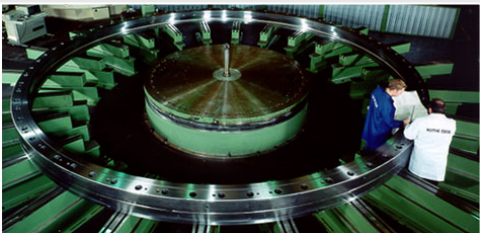

- Portfolio with strong regional and global market positions
- High technological competencies throughout product portfolio
- World market leader in large-diameter bearings, e.g. for general engineering applications as well as solar and wind power plants
- World market leader for engine, transmission, axle and steering assembly systems
- Technology leader in body-in-white equipment

ThyssenKrupp Services: Materials + Serv



- One of the world's leading full-range suppliers of carbon and stainless steel, tubes, nonferrous metals and plastics
- Leading materials service provider in Germany and Europe and one of the leading suppliers of special products in North America
- Services: Materials and applications advice, warehousing, processing, project and inventory management, just-in-time logistics
- After portfolio streamlining the new "Industrial Services" will offer: industrial services incl. maintenance of plant and machinery as well as a wide range of production-related services, scaffold services, as well as technical, infrastructural and commercial facility management for key automotive, steel, chemical and petrochemical sectors
- Number one maintenance operation in Germany, among the leaders in Europe
- Number one worldwide in scaffolding services



Portfolio optimization through focusing

Structural changes since the merger
(fiscal 1998/99 to 2002/03)

Sales (billion €)

	Activities disposed of/ for disposal	Core activities	Group (total)
1998/99	8.4	21.4	29.8
2002/03	4.8	31.3	36.1
Ave. growth		10.0%	4.9%

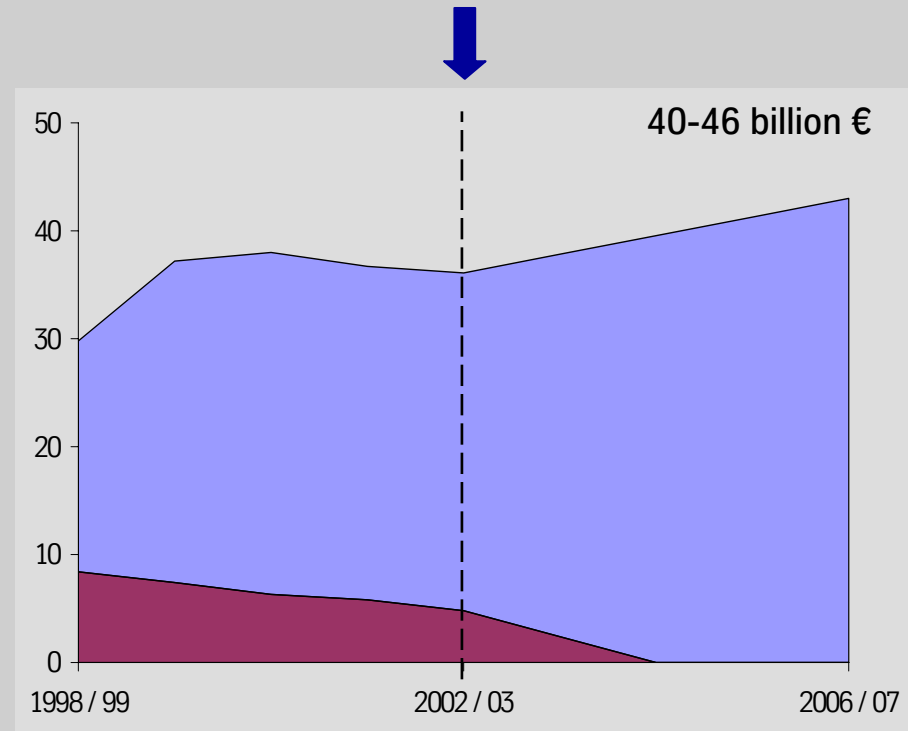

- Core activities
- Non-strategic activities



30+ Portfolio Optimizations in 2002/03

Corporate

Böhler Thyssen Schweißtechnik (D) **Disposal**

Steel

Galmed (E) **Acquisition**
 Quarto plate activities (D) **Disposal**
 LA.RE. (I) **Disposal**
 TAD (I) **Acquisition**
 Fischer (F) **Closure**
 Bauelemente Dinslaken (D) **Closure**

Automotive

Greening Donald (CAN) **Disposal**
 Sofedit (F) **Acquisition**
 Phillips & Temro (USA) **Disposal**
 Philadelphia Plant (USA) **Closure**
 Kendalville (USA) **Mothballed**
 MB Lenk (D) **Acquisition***

Materials

Ferrosta (CZ) **Acquisition**
 Rodena (DK) **Acquisition**
 Werkzeugstahl (D) **Disposal**
 Verder Kunststoffen (NL) **Acquisition**
 Metal Center Rochester (USA) **Acquisition**
 TW Metals (USA) **Acquisition**

Elevator

Lift Service Lublin (PL) **Acquisition**
 ECE Elevator (India) **Acquisition**
 Mahkota (Malaysia) **Acquisition**
 Ascensores Causi (E) **Acquisition**
 Bongear/Hang Pak (Hong Kong) **Acquisition**
 Britannic Lift Co. (GB) **Acquisition**
 Tepper Aufzüge (D) **Acquisition**
 HABAG (D) **Acquisition**
 Mylau Plant (D) **Closure**
 TK Herouth Ltd. Partnership (ISR) **Acquisition**
 DongYang Elevator (South Korea) **Acquisition***

Technologies

Polymer (D) **Disposal**
 Otto India (India) **Disposal**
 Stahlbau Berlin (D) **Closure**
 Henschel (D) **Disposal**
 Novoferm (D) **Disposal***

Serv

Rodisola (E) **Acquisition**
 Umweltservice (D) **Disposal**
 Construction Services (D) **Disposal**
 Media Services (D) **Disposal**

* closing after Sept. 30, 2003



Portfolio Optimization – Disposals in 2002/03

	Number of Entities	Sales	EBT	Net Financial Debt	Pension Obligations	Employees
9 Months	11*	€752 m	-€3 m	€155 m	€13 m	3,707
4th Quarter	1	€167 m	€4 m	€87 m	€6 m	822
Total	12	€919 m	€1 m	€242 m	€19 m	4,529
Subsequent Event	1	€327 m	€8 m	€1 m	€14 m	2,177

* incl. non-consolidated entities



Portfolio Optimization – Major Acquisitions in 2002/03

	Sales	EBT	Transaction Volume	Employees	Status
Galmed, Spain Steel Hot dip galvanizer; access to high-growth Spanish automobile market; further step in internationalization of downstream activities	≈€100 m	+	€51 m	≈60	consolidated
Tepper Aufzüge, Germany Elevator Biggest elevator manufacturer in NRW; further strengthening market position in Germany	≈€40 m	+	€42 m	≈300	consolidated
Sofedit, France Automotive French supplier, further strengthening position in OEM market	≈€600 m	+	€66 m*	≈4,000	consolidated
DongYang, South Korea Elevator Strengthen the segment's market position in Asia, especially in Korea	≈€200 m	+	not disclosed	≈1,000	closed
MB Lenk, Germany Automotive Competence in steering gears; further step to becoming major global player in steering systems	≈€300 m	+	€42 m	≈1,600	closed

* excl. factoring



ThyssenKrupp Group Workforce

Movements during the past 4 fiscal years

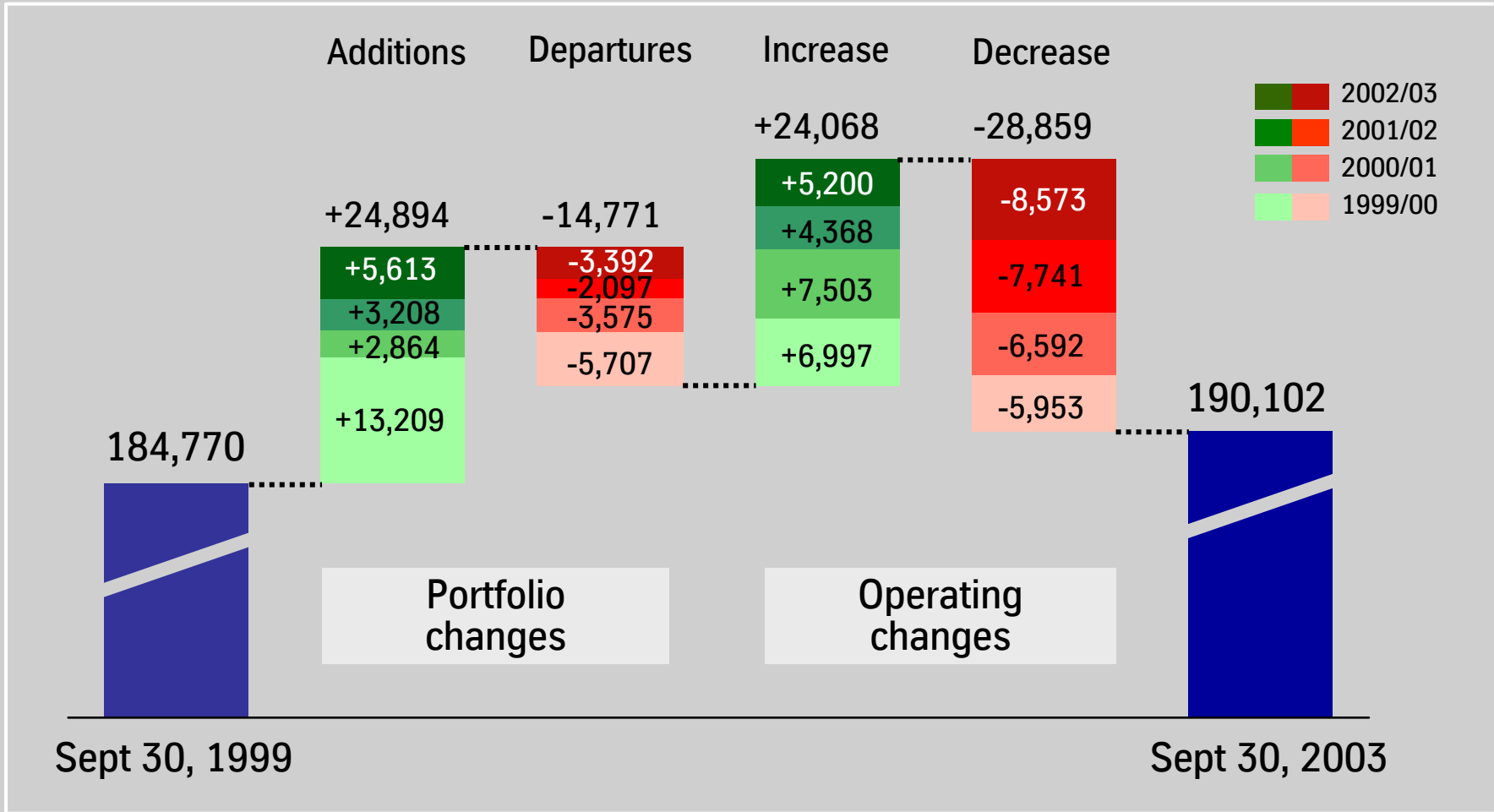

2002/03 – Overview (I)

Despite an adverse environment ThyssenKrupp held up well and achieved significant performance improvements

The adverse factors we had to weather:

- Economic headwind, mainly in key industries
- Strong appreciation of the euro against the US dollar
- Rating downgrade in February 2003
- Forced share repurchase in May 2003



2002/03 – Overview (II)

Despite an adverse environment ThyssenKrupp held up well and achieved significant performance improvements

- Although sales and orders were down (incl. currency effects), we achieved a significant improvement in normalized EBT from €419 million to €734 million
- This signifies the improvement in quality of our earnings: efficiency enhancement program (TK best) continues to make an impact
- Adjusted for a positive tax effect and disposal effects, EPS climbed to €0.89 from €0.48; in line with earnings improvement increased dividend of €0.50 per share will be proposed
- Against September 30, 2002 net financial payables were reduced by €0.5 billion to €4.2 billion; despite the forced share repurchase of €406 million, gearing is significantly below 60%



2002/03 – Overview (III)

Major achievements in the segments

- Price stabilization in Carbon Steel

- Ongoing significant earnings and value contribution from Elevator

- Positive value contribution from Automotive

- Streamlining of the portfolio at Technologies and Serv (including a €61million loss from sale of Construction Services)

- As of October 1, 2003 the former segments Materials and Serv were combined into the new segment Services to focus materials competency and industrial services



2002/03 – Overview (IV)

Optimization of the portfolio

- Focus on disposal program of over 30 non-strategic or low performing investments; companies with sales of €5 billion still to be divested

- Since the beginning of fiscal 2002/03 a total sales volume of €1.0 billion have been disposed of and acquisitions with sales of €1.5 billion have been closed

- We actively continue to pursue our 2002/03 strategy and stick tight to our investment policy



Group

EBT

million €

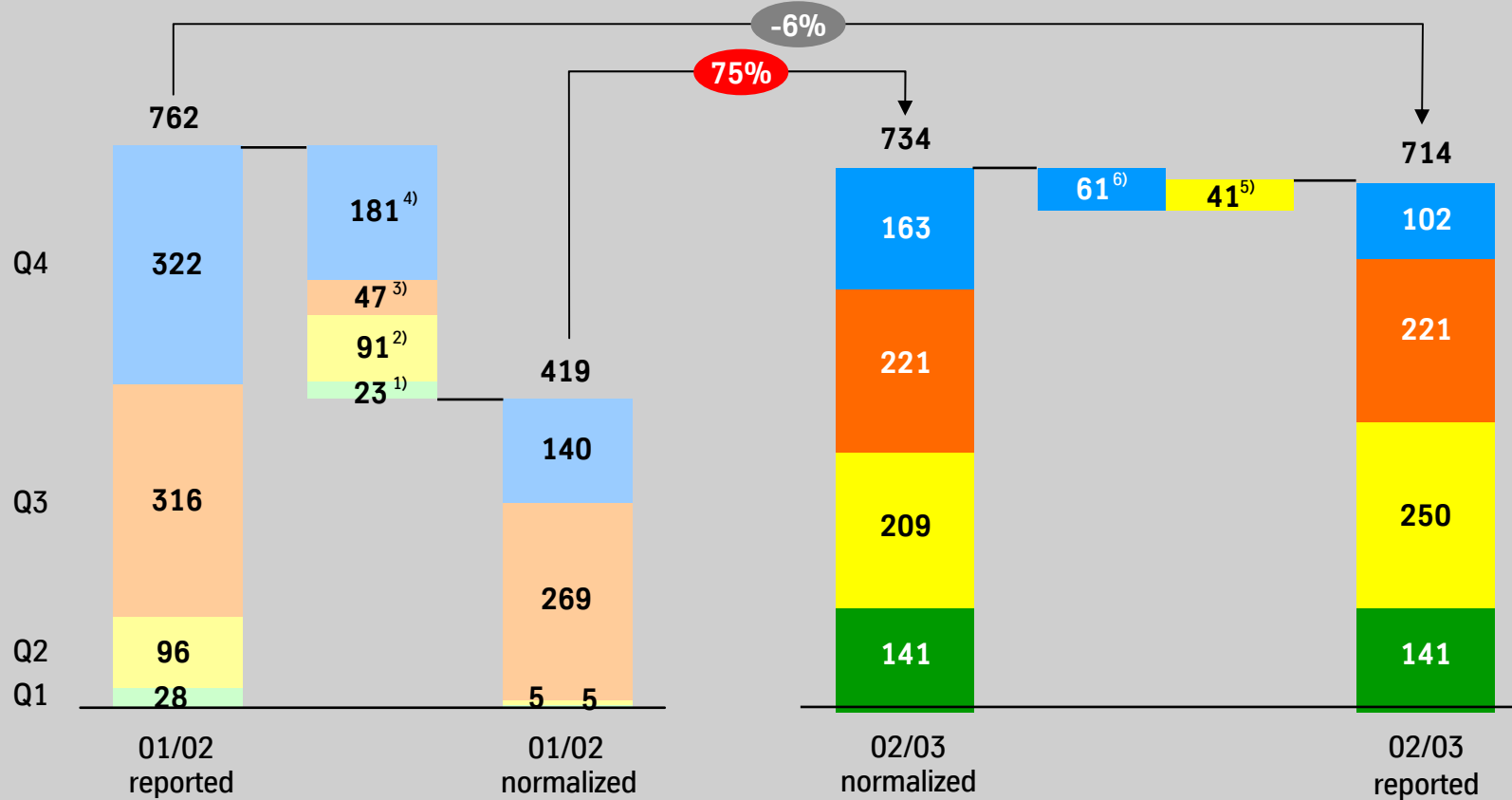

¹⁾ Sale of Kone shares €23 m
²⁾ Sale of Kone shares €51 m / Eurawasser €19 m / Sinterstahl €21 m
³⁾ Sale of Berco Bautechnik €36 m / Casting activities €11 m
⁴⁾ Sale of Ruhrgas shareholding €191 m / Car carrier activities -€10 m

⁵⁾ Sale of stainless quarto plate activities €41 m
⁶⁾ Sale of construction services -€61 m



Balance Sheet

Progression of net financial payables

million €

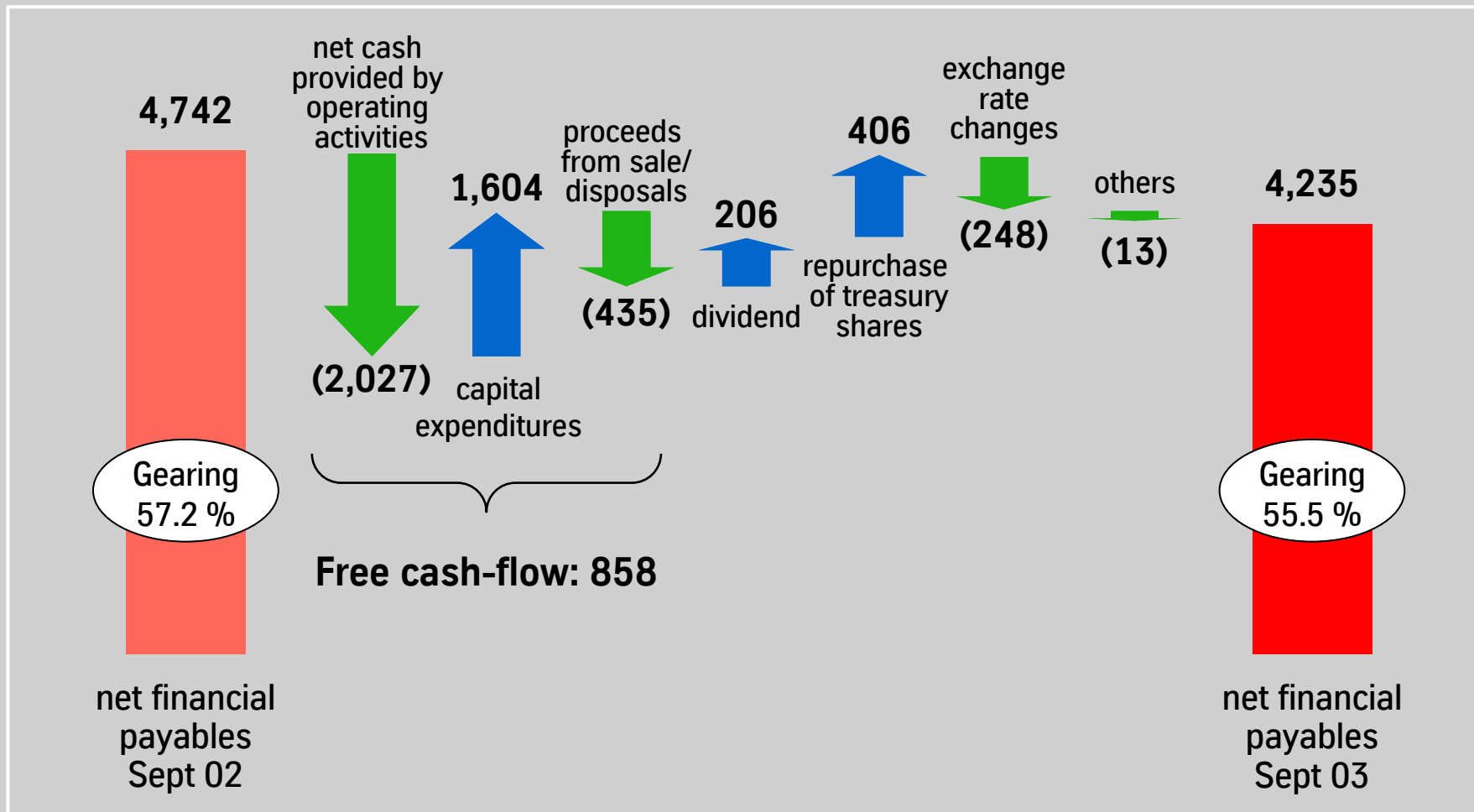

Outlook

- The uncertainties over the economic outlook persist at the beginning of the new fiscal year. Most forecasts predict only a moderate recovery for 2004. If the widely forecast weak economic recovery materializes, this would of course also benefit our business performance.
- In fiscal year 2003/04 we aim to achieve a significant increase in normalized earnings before taxes.
- We will continue to pay a dividend based on our earnings performance.



Cross Segment Development of Client Solutions

ThyssenKrupp capabilities for the automotive industry

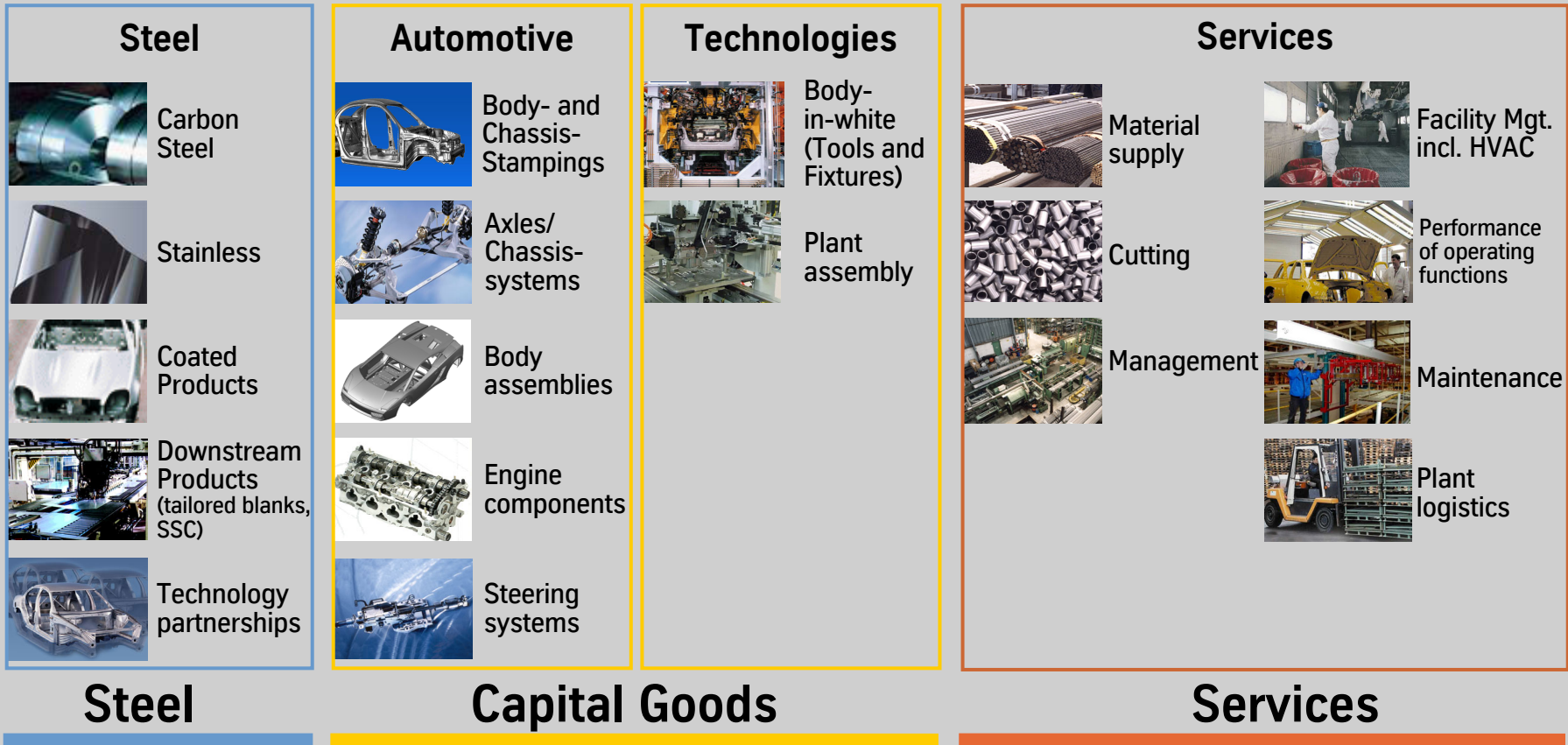

Sales with automotive clients: ~€10 bn

ThyssenKrupp Innovations (I)

Steel design wheels with Nirosta® cover

- High-quality appearance
- Integrated design flexibility
- Lighter and lower in cost than cast aluminum wheels



Off-road stabilizers for sport utility vehicles



- Stiff suspension
- High damping
- Stabilizers with high torsional rigidity
- Soft suspension
- Low damping
- Stabilizers with very low torsional rigidity



Stabilizer can be switched hydraulically under load

Steel sheet piling and top structures for flood protection systems

- System solution for effective and economic flood protection
- Combination of engineering expertise, environmentally compatible materials and advanced equipment technology



TWIN elevator

- Production-ready elevator system with two independent cabs in one shaft
- Higher transportation performance using fewer shafts

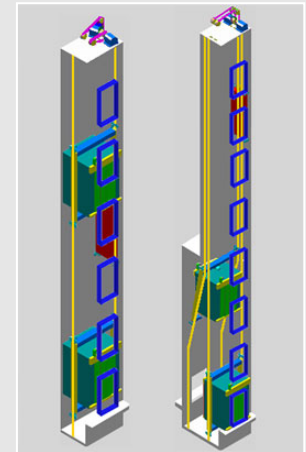

ThyssenKrupp Innovations (II)

NewSteelBody

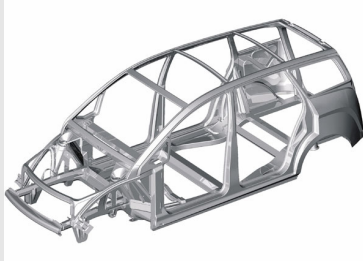

- ThyssenKrupp Stahl designed a complete weight-optimized steel body-in-white
- Open source project to interested auto manufacturers for joint further development
- Reference vehicle is the Opel Zafira
- The body developed under the project is 24% lighter than the reference vehicle

Innovative air suspension system for the new Jaguar XJ



- Air suspension which has considerable comfort advantages over conventional spring suspensions
- The system ensures that the entire spring travel is permanently available, regardless of vehicle load, to compensate for uneven road surfaces

Modular door from ThyssenKrupp Stahl and Nothelfer



- The new, modular door is 12 kilograms lighter than the benchmarked model and costs significantly less to manufacture and assemble
- The modular approach means that door production and door assembly can be separated

Preprimed sheet: organic coated steel

- The prepainted sheet already has half of the paint system needed for body outer parts
- The usual paint system applied by car manufacturers consists of primer, filler, top coat and clear coat
- The aim of the project is to supply the auto industry increasingly with prepainted sheet from coil
- The process produces extremely uniform coatings of consistently high quality

Conclusion

- ThyssenKrupp: Focused industrial group based on 3 pillars
- High degree of internationalization: Focusing on Asia and China
- Still a conglomerate combining value and growth components
- Clear strategic direction: Portfolio optimization will be forced
- Cross segment development: Driver for innovations

