

SloanLED Prism

Installation Guide for 701269-(XX)SJ(Y)-MB

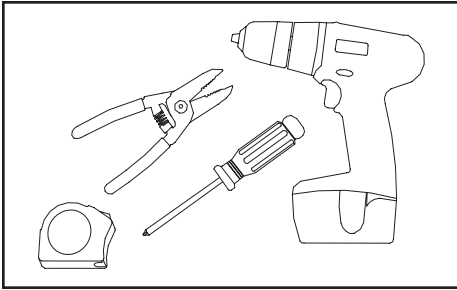

1. **Tools required:** Measuring tape, wire strippers. **Optional:** Drill, screwdriver.

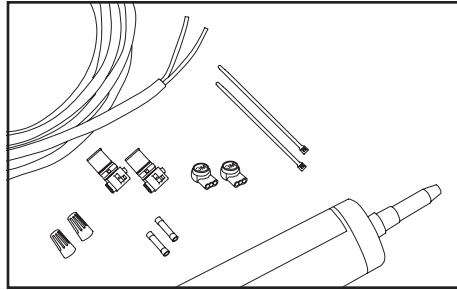

2. **Supplies required:** PLTC cable, wire nuts, IDC connectors or butt splices with appropriate safety agency markings, and cable ties. **Optional:** Screws and silicone.

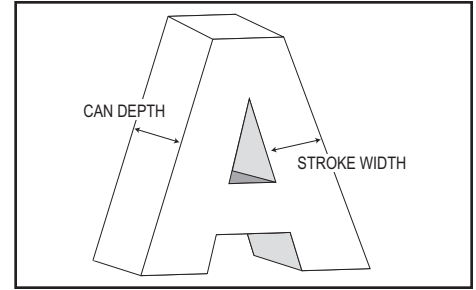

3. **Layout:** To populate sign, refer to SloanLED® Prism density guidelines, test, or contact your SloanLED Representative for recommendations.

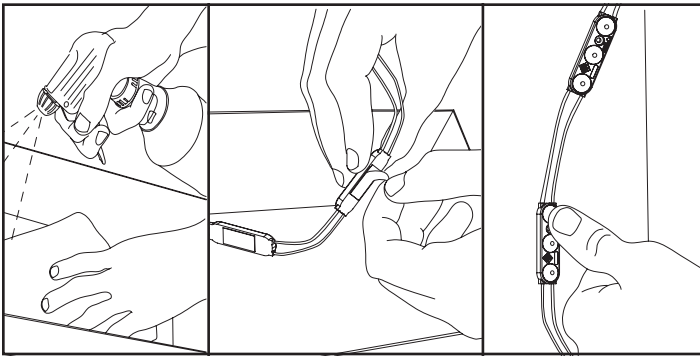

4. **Peel and stick:** Clean inside sign with rubbing alcohol and allow to dry. Using predetermined layout and LED placement from Step 3, remove tape backing and stick modules into place. Ensure modules are firmly attached.

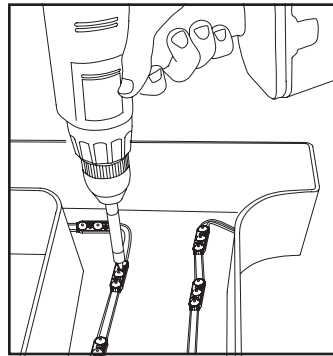

5. **Fasteners:** If desired, modules can be secured with #6 (3.5 mm) pan head sheet metal screws or 1/8 in (3 mm) aluminum rivets.

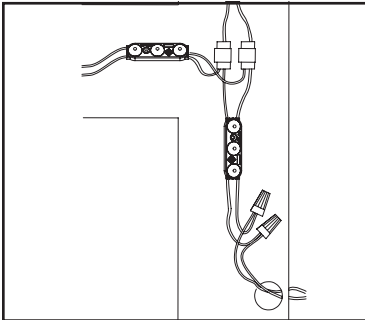

WARNING:
Connect Red striped wire of LED modules (+) to Red wire of power supply (+). Connect White wire of LED modules (-) to Black wire of power supply (-). Reverse polarity connections may damage LEDs and will void product warranty.

6. **Connections:** Modules may be connected in series or parallel.

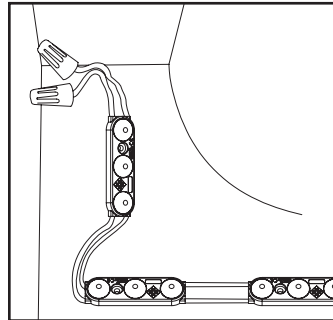

7. **Cap all unused wires:** The strand of modules should not be looped to create a closed circuit.

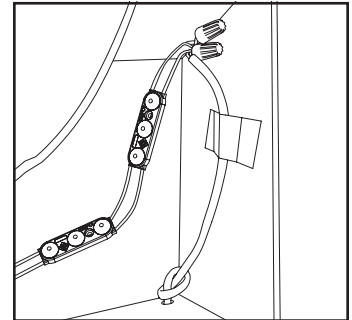

8. **Connect power supply to first module on string:** See power supply install guide for more information regarding power supply installation.

Installation Guide for 701269-(XX)SJ(Y)-MB

12 VDC Power Supply Capacity Chart

Power supply	Part number	Input		Output		Maximum feet (meters) / modules			
		Nominal input voltage	Input current	Power output	Output current	White 7100 K, 6500 K, 5000 K, 4000 K, 3000 K (1.5/ft, 4.9/m)	White 6500 K (1/ft, 3.3/m)	Red, Orange, Green, Blue (1.5/ft, 4.9/m)	Red (2/ft, 6.6/m)
Self-Contained 20 W	701680	100-240 V	0.55 A	20 W	1.5 A	10 (3.3)/16 modules	16 (4.8)/16 modules	16.6 (5.1)/25 modules	12.5 (3.8)/25 modules
Compact 12/25 W	410174	100-277 V	0.40 A	25 W	2.1 A	13.3 (4)/20 modules	20 (6.1)/20 modules	20.7 (6.3)/31 modules	15.5 (4.7)/31 modules
60C1 60 W	701507-60C1	100-277 V	0.70 A	60 W	4.5 A	32 (9.8)/48 modules	48 (14.6)/48 modules	50 (15.2)/75 modules	37.5 (11.4)/75 modules
60W1 60 W	701507-60W1	100-240 V	0.85 A						
MODW(E) 60 W	701507-MODW(E)	100-240 V	1.00 A						
MOD277 60 W	701507-MOD277	277-347 V	0.50 A						
120D1 120 W	701507-120D1	100-277 V	1.70 A	2 × 60 W	2 × 4.5 A	2 × 32 (9.8)/48 modules	2 × 48 (14.6)/48 modules	2 × 50 (15.2)/75 modules	2 × 37.5 (11.4)/75 modules
Power used per foot (meter) in watts						1.69 W (5.54)	1.13 W (3.71)	1.08 W (3.55)	1.44 W (4.72)

NOTE: Each 12 V circuit must be limited to 5 A (60 W) or less. For North American installations, a power supply that meets NEC Class 2 specifications is required.

Extension of Power Supply Leads

If longer lead wire from power supply to LED modules is needed, an extension can be used. Extension should be kept as short as possible, i.e., under 15 ft for 18 AWG UL Listed PLTC (4.6 m for 1 mm² PLTC) or under 50 ft for 14 AWG UL Listed PLTC (15.2 m for 2.5 mm² PLTC).

Troubleshooting

NOTE: A licensed electrician should perform all applicable steps.	
Entire sign or leg does not light after complete installation	Check connection from power supply lead to first module. Make sure polarity of connections made at the power supply lead and any jumper wire is correct. Power supply outputs should be connected RED-TO-RED and BLACK-TO-WHITE.
Still does not light	Check output voltage of power supply using a voltmeter. The output voltage should be DC 12.0 V ± 0.5 V. If there is no output voltage, have a licensed electrician check input voltage. Make sure power supply is connected correctly and getting primary power. If power supply is connected properly and getting primary power and there is still no output voltage, try a different power supply.
Still does not light	If power supply is getting primary power and the modules don't light, there may be a short in the secondary wiring. Check all connections and cap all loose wires.
The beginning of a leg lights, but the entire leg does not light or lights intermittently	The primary cause of a portion of a SloanLED Prism leg not lighting or lighting intermittently is a bad connection or reverse polarity connection between the modules that light and the modules that don't light. Check this connection.
One module does not light, but all others in the leg light	SloanLED Prism is designed so if one module fails, it will not cause the entire sign or leg to go out. If one module does not light, but all others in the leg do, replace this module with a new one.

SloanLED Prism is covered by US patent 6,932,495 and US and foreign patents pending.

