

LSK05-01

Laser welding and clamping head - one head, many possibilities

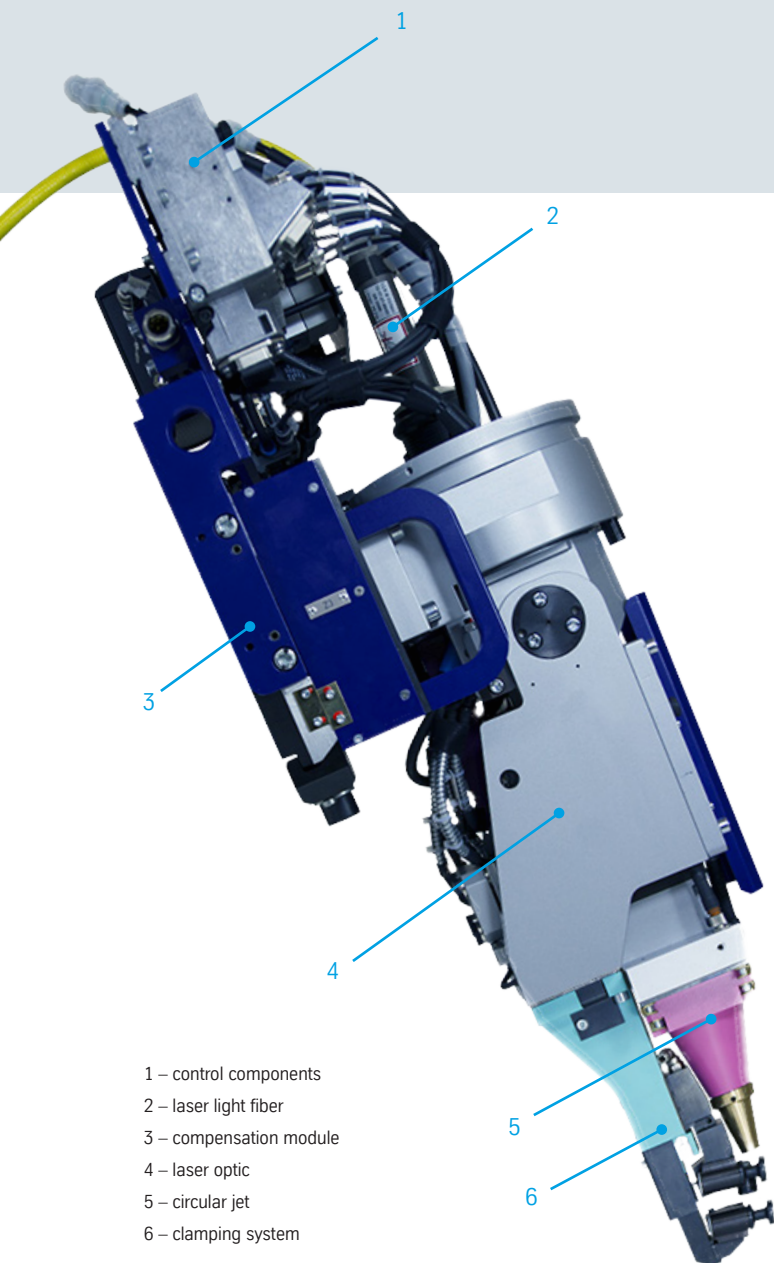

Description

- Manufacture of exact and low-tension welded components thanks to patented roller clamping technology (also for high-strength material)
- Cost reduction through simplified equipment
- Adaption to various joining geometries through modular construction and particular function groups (tools)
- Very good access to parts through extremely light construction
- Minimal flange width (up to 6 mm) thanks to patented clamping system
- Zinc degassing through patented degassing system
- Thermo mechanical degassing or aimed creation of a degassing gap by vario clamping technique
- Adjustable tension force between 100 and 700 N
- Adaptation to the component geometry by special function groups
- High protection glass life time by flow and fuel-efficient circular jet (< 350 l/min)
- Improved protection of the optical components by 2nd protection glass
- Control and diagnostics via fieldbus (e.g. Interbus, Profibus, Profinet)
- Minimal maintenance and repair costs by the use of high quality components
- Fast repair thanks to pre-installed spare parts kit and wear parts kit
- Online process maintenance possible



LSK 05-01

Technical data

General data

Dimension (L x W x H) without camera	[mm]	830 x 400 x 260
Mass base module for diode laser (LDF4000-30)	[kg]	approx. 36
Mass base module for disc and fiber laser	[kg]	approx. 30
Mass tool LSK 05-14-000-R010/R000	[kg]	approx. 3
Mass vario clamping tool LSK 05-25-000-R010/R000	[kg]	approx. 5
Environmental temperature	[°C]	+15 to +35
Relative air moisture at production site (no condensation)	[%]	up to 85
Optic for laser power (other at request) laser beam class 4	[kW]	≤ 4
Focal distance	[mm]	200
Optic for diode laser		Co. Laserline
Optic for disc and fiber laser		Co. Trumpf
Wave length laser light (Diode laser LDF 4000-30)	[nm]	880 - 1080
Wave length laser light (Disc and Fiber laser)	[nm]	1030 - 1080
Core diameter of used laser light cable	[µm]	≤ 600
Diameter of focus at 600 µm laser light cable	[mm]	0,6
Reproduction scale		1:1
Width of flange min.	[mm]	7
Clamping force	[N]	100 to 700
Compensation vertical to cut flange in sheet level (Y-compensation)	[mm]	±5
Compensation vertical to flange (Z-compensation)	[mm]	±5
Rotation angle of axis 7 (potential adjustment)	[°]	-180 - +135
	manual	[°] grid 15°

Pneumatically interface

Air pressure 1 plug in	for Tube Tubo PU 8	[mm]	12
		[mm]	14 at request
Air pressure		[MPa]	0,6
Compressed air unooled, dry	filtered to	µ	0,1
Usage of compressed air at 0,6 MPa max.		[l/min]	approx. 350

Cooling water interface

Plug in for cooling water	2x Tube	[mm]	6
Connection at LSK	Fa. Rectus		21SBTF04DPX
Quality of cooling water	deionized water	µS	approx. 1 - 200
Temperature of cooling water	Avoid of condensation!	[°C]	+15 to +30
Min. cooling power for each system		[W]	>750

Electrical interface

Fieldbus plug		
Power supply for digital in/output - modules at valve block	[V]	24 DC
Control voltage	[V]	24 DC
Power output	[W]	30
Degree of protection		IP 54

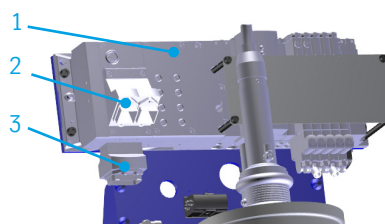

- 1 – digital in/output module
- 2 – fieldbus connection
- 3 – control voltage connection



LSK 05-01

Special function groups to match with component geometry

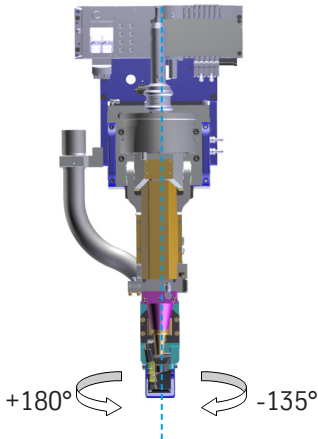
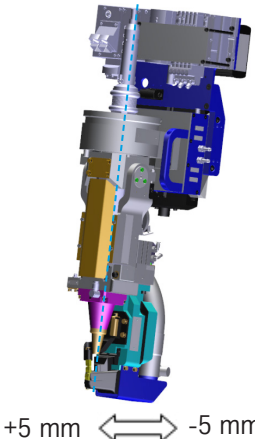
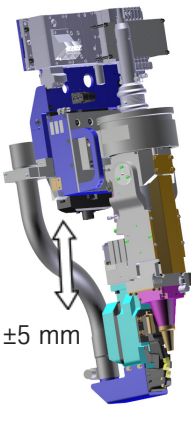
Axis 7	Y-compensation	Z-compensation
Reduced repositioning cycles Increase of component accessibility and radius welding speed	Adjustable distance of weld seam to flange Compensation of trimming and positioning tolerances	Integrated weight compensation Compensation of tolerances and dead weight
 <p>+180° ↻ ↻ -135°</p> <p>Manual adjustment: Grid 15°</p>	 <p>+5 mm ↔ -5 mm</p> <p>Pressing force $F = 50 - 360 \text{ N}$ manually adjustable</p>	 <p>±5 mm</p> <p>Residual force remaining on component $F \leq 50 \text{ N}$ by dead weight</p>

References

Volkswagen

Plants:

- Germany/Wolfsburg
- Germany/Emden
- Germany/Zwickau
- China/Shanghai
- China/Foshan
- Mexico
- Brazil

Models:

- Touran
- Golf A6/A7
- Golf Plus
- Passat B7/B8
- Tiguan/Model K

PSA

Plants:

- Spain/Vigo
- Spain/Aimen

Model:

- C4 Picasso 5/7

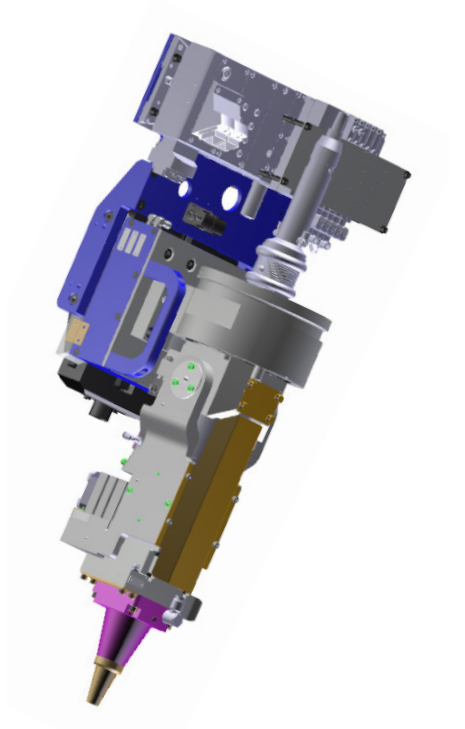



LSK 05-01

Application examples with various tools

LSK 05-25
Vario clamping tool

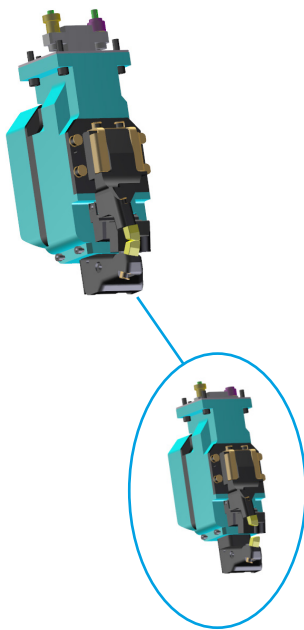

LSK 05-14
Standard clamping tool

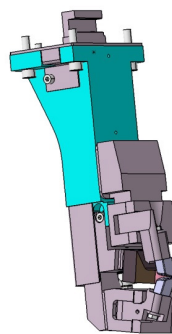

LSK 05-13
Tool with double roll

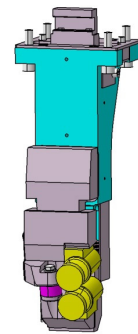

Laser power ≤ 4 kW at welding speed from 20-110 mm/s (max. speed depending on robot)

Contact

thyssenkrupp System Engineering GmbH
Schlossstraße 22
D-66687 Wadern-Lockweiler
Germany

florian.nicolaus@thyssenkrupp.com
www.thyssenkrupp-system-engineering.com

© 2017 Product specifications and prices are subject to change without notice or obligation. The photographs and/or drawings in this document are for illustration purposes only. The operation values are considered to be approximate and will be finally determined on the basis of the specific task and the material characteristics. The only warranty applicable to our equipment is the standard written warranty applicable to the particular product and sale and thyssenkrupp makes no other warranty of accuracy, reliability, completeness, merchantability or fitness for any purpose, express or implied. Products and services listed may be trademarks, service marks or trade-names of thyssenkrupp and/or its subsidiaries in Germany and other countries. All rights are reserved.