



thyssenkrupp

# thyssenkrupp Automotive Technology

## Company Presentation

thyssenkrupp AT | April 2026

engineering.tomorrow.together.

# Our businesses in figures

Fiscal year 2024/25

## Automotive Technology



7.03 billion EUR (-7%)  
Sales

187 million EUR (-24%)  
Adjusted EBIT

28,892  
Employees

## Decarbon Technologies



3.4 billion EUR (-10%)

71 million EUR (++)

12,335

## Materials Services



11.4 billion EUR (-6%)

132 million EUR (-35%)

15,433

## Steel Europe



9.8 billion EUR (-9%)

337 million EUR (+29%)

25,993

## Marine Systems<sup>1</sup>



2.2 billion EUR (+3%)

127 million EUR (+1%)

8,585

((changes compared to previous year))

1: Since October 20, 2025, TKMS (Marine Systems segment) has been an independent and publicly traded system provider in the maritime defense market.



# Automotive Technology

Dependable partner to the auto industry

**€7.035 bn**

Sales

**€187 million**

Adjusted EBIT

**28,892**

Employees

Automotive Technology is the automotive division of thyssenkrupp. The segment develops and manufactures **chassis, powertrain, and body technologies** as well as **system solutions** for the international automotive industry. Automotive Technology operates a global production network with sites in Europe, Asia, and North and South America.

With a customer- and technology-oriented structure comprising four business units – **Chassis, Components, Aftermarket, and Forging** – the segment consolidates its growth-driven activities, sharpening customer focus and efficiency. This setup enables targeted benefits from technological transformation and the rising demand in markets such as **China** and in the field of **electromobility**.



# Automotive Technology Business Units

Bilstein Motion Solutions<sup>1</sup>

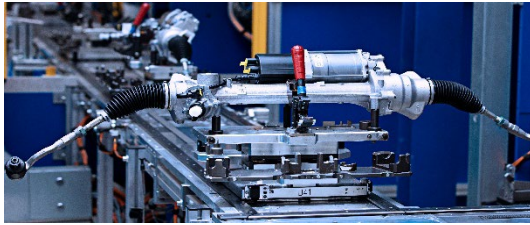

Presta Dynamic Components<sup>1</sup>



Aftermarket Group<sup>1</sup>



Forged Tech<sup>1</sup>



Springs & Stabilizers<sup>2</sup>



Automotive Body Solutions<sup>2</sup>

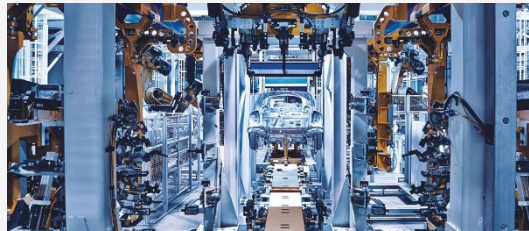

Automation Engineering<sup>2,3</sup>



<sup>1</sup> The Automotive Technology segment has aligned its portfolio around four customer- and technology-focused areas: Chassis, Components, Aftermarket and Forged Business.

<sup>2</sup> For the business units Automotive Body Solutions, Automation Engineering, and Springs & Stabilizers, separate new development options are being evaluated.

<sup>3</sup> The Automation Engineering business unit was sold to Agile Robots SE with effect as of March 31, 2026, and is no longer part of the thyssenkrupp Group.



# Automotive Technology – Partner for components, systems and services in the Automotive Industry

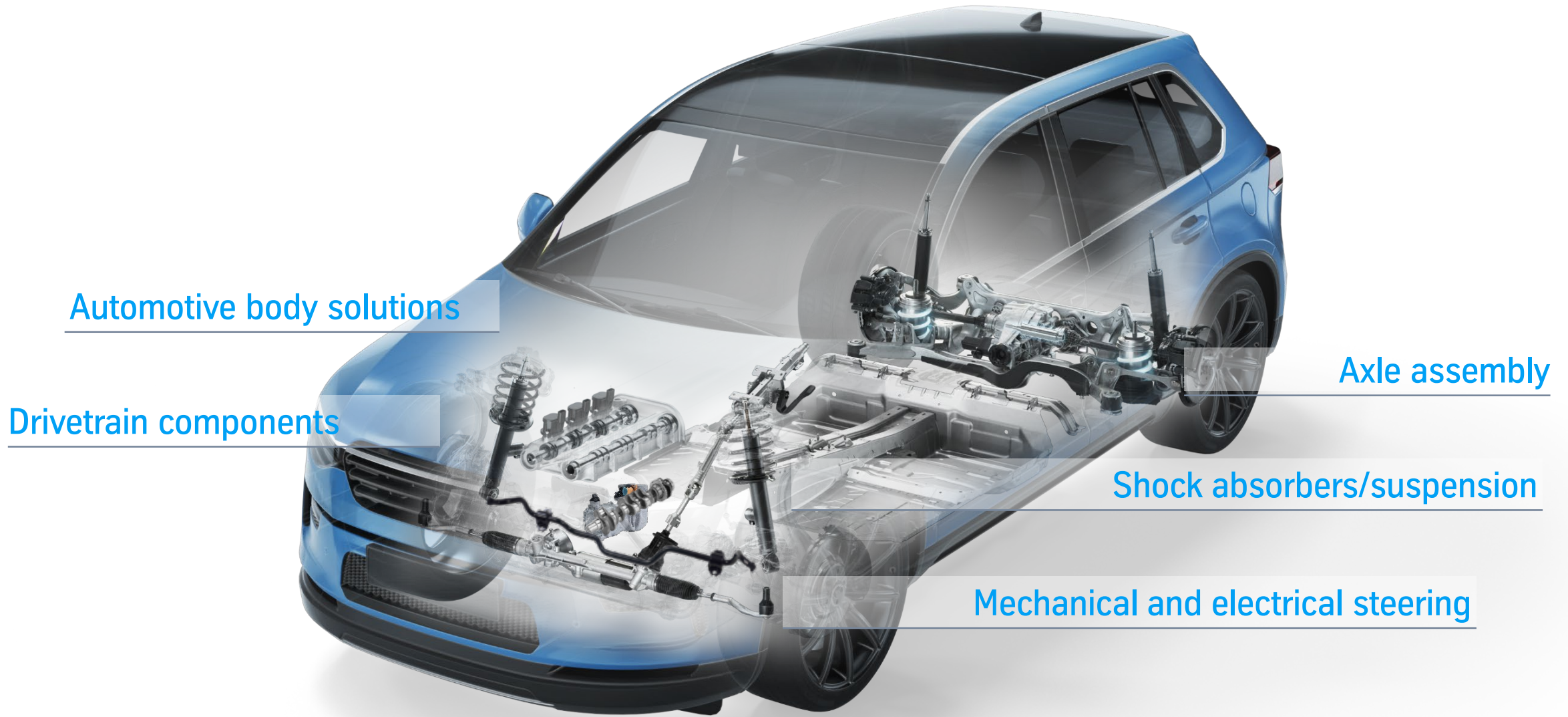

1. Excluding SP, AE



# Our strength: Integrated value chain

Focus on efficient, robust processes and innovative solutions



## Engineering

- Research & Development
- Prototyping
- Testing

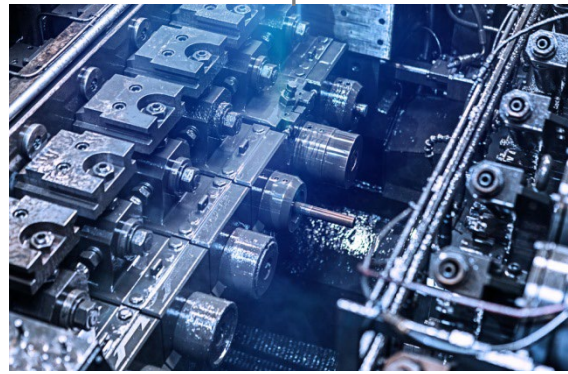

## Material processing

- Material competence
- Forging
- Standardization

Efficiency & quality

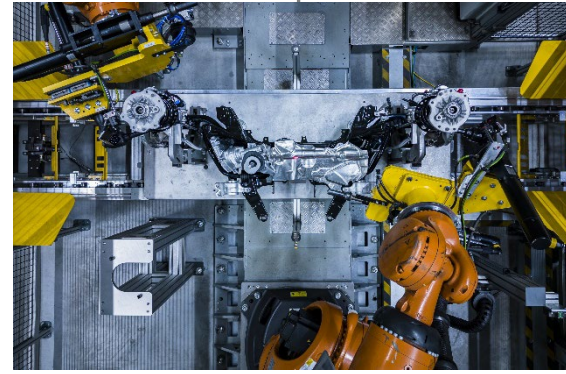

## Machining & assembly

- Process competence (low-  
/high-volumes)
- Automation
- Quality management



## System integration













- Plant engineering
- Just-in-time delivery
- Electronic integration
- Model assembly

Innovative solutions





# Business Segment Automotive Technology: About 80 production sites worldwide



## Europe

- |   |  |   |   |  |  |
|---|--|---|---|--|--|
|  France  |  United Kingdom |  Germany |  Poland      |  Portugal |  Italy    |
|  Romania |  Liechtenstein  |  Hungary |  Switzerland |  Spain    |  Bulgaria |

## America

- |   |
|---|
|  USA     |
|  Mexico |
|  Brazil |

## Asia

- |       |   |
|-------|---|
| China |    |
| India |  |



# BU Bilstein Motion Solutions



# Products – Steering

24 sites worldwide

## Mechanic & Electric Systems



Single components and systems for steering torque transmission, steering wheel position adjustment, crash energy absorption and interfaces to the vehicle environment

## Mechatronic Systems



Full range of layouts, assistance levels and safety goals of brushless motor driven electrically powered steering systems (EPS).

## Software



Low and high level software for the safety and functionality of all steering systems. Software modules for the interaction of steering, powertrain, brakes and dampers.

## Advanced Engineering



Stand-alone and OEM-cooperation in the fields of innovations and future mobility. Steer-by-Wire, Autonomous Drive, Vehicle Motion Control, Brake-by-Wire, etc.

## Inhouse Services



Concept, simulation, prototypes and test bench validation. Testing with modular demonstrator vehicles and in customer vehicles. Benchmark competition systems.



# Products – Dampers & Suspension struts

9 sites worldwide

## Conventional/passive dampers



The classic hydraulic gas-pressure shock absorber is used in most automobiles today. For our partners in the auto industry we are constantly developing new solutions to improve road holding and driving enjoyment.

## Semi-active dampers



Sensors detect the current driving situation. A control unit records this information and optimizes the damping force for each damper individually. This provides greater safety as well as higher driving comfort.

## eSuspension



Equipped with the innovative combination of a conventional controlled shock absorber and an active hydraulic cylinder, eSuspension technology enables fully active adjustment of the suspension to any driving situation - for an unprecedented feeling of comfort in any driving situation.



# Products and Services – Axle assembly & System solutions for car chassis

9 sites worldwide

## Module assembly



Module assembly includes the assembly of individual components that are grouped into smaller assembly units and ordered separately by the OEM.

## System assembly

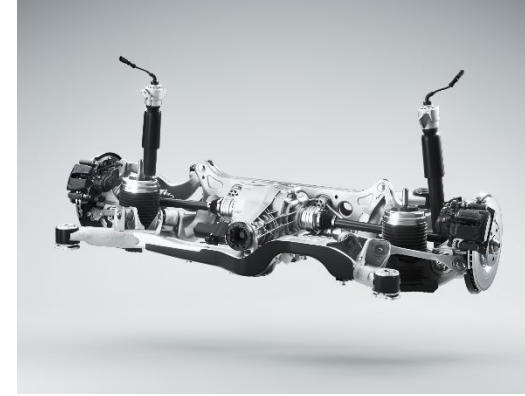

As a reliable JIS/JIT expert, we reduce complexity in our customers' manufacturing processes by managing all procurement and assembly processes, from standard products to safety-related assemblies. Our solutions are always customized to the customer's needs, and we are constantly developing our service portfolio. Specially installed assembly lines are used for these complex systems.

## Just-in-sequence/Just-in-time



We deliver chassis systems to OEMs just-in-time and just-in-sequence. Though synchronous with the sequence of the production requires the utmost from systems and processes. We manage all processes from supplier management to just in sequence assembly and delivery of ready to install systems.

## Other services



We plan, implement and coordinate the complete supply chain. Up to 1,200 individual components from approx. 150 suppliers in over 12 countries are controlled per location. Around 70,000 transport journeys annually across 4 continents are coordinated. In addition to that, we provide quality management services for the entire supply chain.



# BU Presta Dynamic Components



# Products – Drivetrain Components | Cold Forging & Steering Components | eA/C Compressor

18 sites worldwide

## Assembled camshafts



The camshaft controls the charge change in the combustion engine. By implementing this as a multi-part component, it is possible to use the optimum material in the right place and reduce the weight.

## Modules

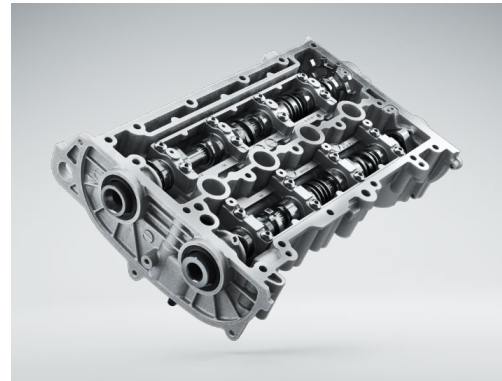

The camshafts are assembled inside of closed module heads or bearing frames to reduce assembling and handling effort. A variable valve train system increases efficiency of the internal combustion engine in wide map ranges.

## Rotor shafts



The rotor shaft is used to hold the laminated core and ensures torque transmission from the electromagnetic area to the mechanical area.

## Cold Forging products



Wide range of cold forged components for unlimited applications in automotive and non-automotive applications. Thanks to state-of-the-art processes and tool systems, we manufacture net-shape or almost near-net-shape parts.

## I-Shafts & Spindles



Spindles and I-Shafts are the base for the internal axis of the column. They transfer torque from the steering wheel to the steering gears. Their main tasks are ensuring length compensation, crash functionality & steering feel.

## eA/C Compressor



The thermal management market is shifting to natural refrigerants like R744 (CO<sub>2</sub>) for environmental reasons, as it is more efficient and non-flammable. To address this, a new compressor was developed for high efficiency and durability,



# BU Aftermarket Group



# Products – Shock absorbers and undercarriage parts

5 sales center worldwide

## BILSTEIN



Passive and (semi-)active damping technologies as well as associated parts for light vehicles in the replacement, upgrade, and performance segment across all markets.

## BERCO

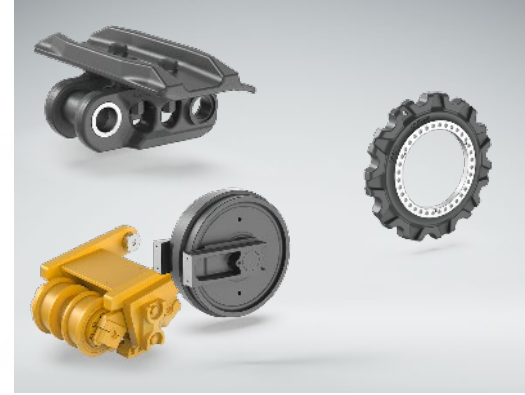

Complete range of undercarriage components for crawler machines (bulldozers, excavators, others) across all market segments (mining, construction, forestry).





# BU Forged Tech



# Products – Forged and machined components

13 sites worldwide

## Engine components



Crankshafts and connection rods are used in nearly every type of combustion engine. These components are critical to successful, trouble-free motor function – and not only now, but over many years.

## Truck chassis parts



Forged and machined front axle beams are a safety critical components for the chassis of trucks. These components are manufactured on one of the world's most efficient forging lines in Homburg, Germany.

## Undercarriages



The thyssenkrupp brand Berco supplies manufacturers and operators of chain-driven construction machinery with a complete range of high-quality undercarriage systems and components.





# BU Springs & Stabilizers



# Products – Springs & Stabilizers

8 sites worldwide

## Coil Springs



We offer a wide range of coil springs, from barrel springs (miniblock springs) and conical springs to side load compensating springs, cylindrical coil springs and ThermoTecSprings®. We are also experts in the design and validation of suitable spring seats, sleeves, and appropriate assembly processes.

## Stabilizer bars



We offer a great portfolio ranging from solid and tubular stabilizers to light weight stabilizer bars for the automobile industry and work towards meeting special requirements for weight reduction, while maintaining the same functionality and long service life.

## Heavy duty business



We also offer leaf springs and heavy stabilizer bars that are typically utilized in heavy duty vehicles and are specifically manufactured to withstand higher vehicle weight. Beside chassis springs we also produce power springs for the application in brake cylinders of trucks.



# BU Automotive Body Solutions

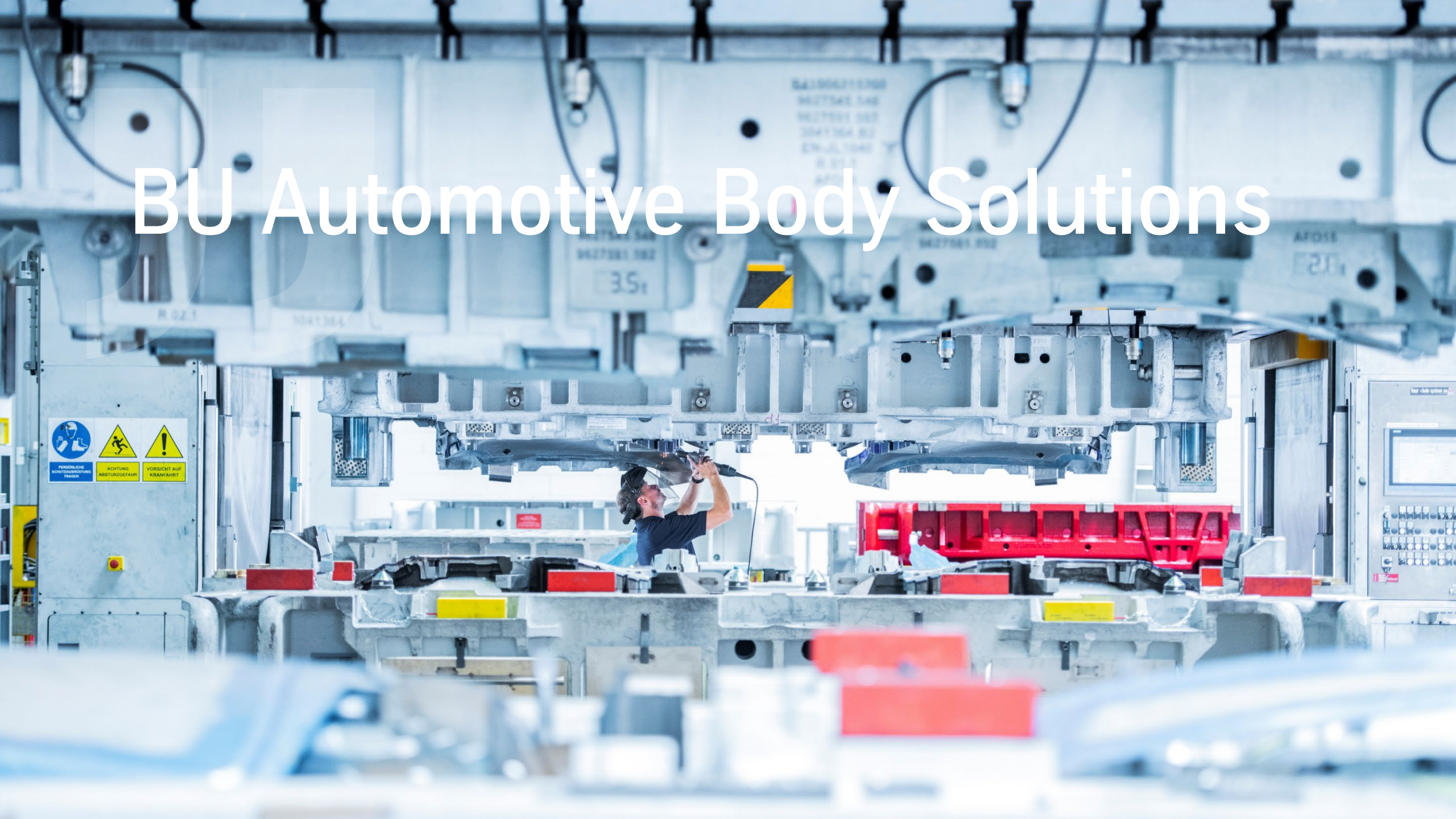

# Services – Car body solutions

9 sites worldwide

## Integrated body solutions



Automotive Body Solutions covers the entire value chain from manufacturing equipment and tooling to car body production. For customers, this offers the advantage that a single supplier assumes overall responsibility for quality and also ensures a very fast and flexible build-up of series production capacities.

## Project business



The project business comprises the operating equipment needed for automotive prototype and series production of car bodies. Our product portfolio ranges from prototype construction, die construction and plant engineering to standard products such as folding, door sealing, laser and adhesive systems.

## Serial production

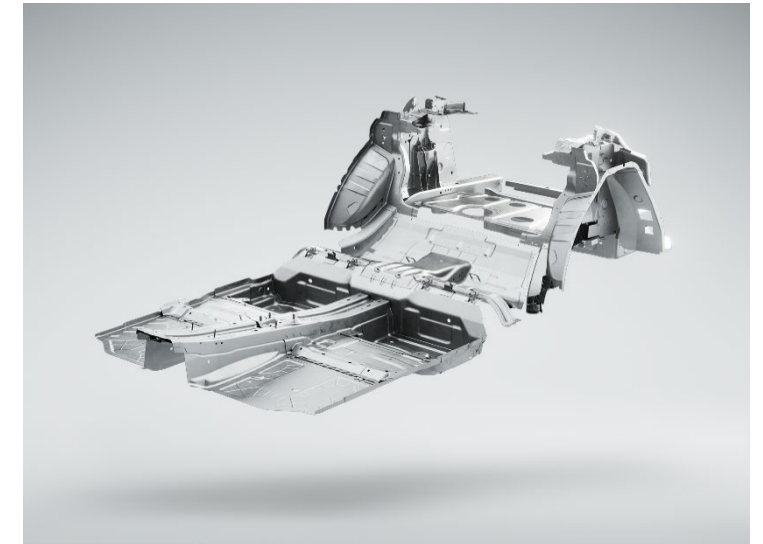

In the area of serial production, our customers will find the right partner for sophisticated and complex body structures and components including ready to paint car bodies.

